

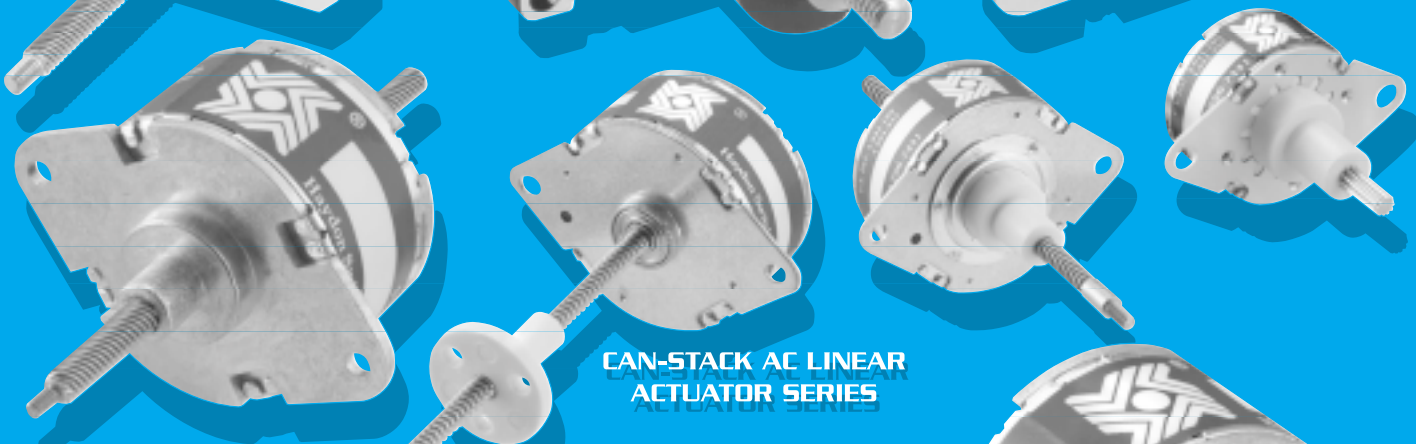

# Haydon Switch and Instrument

AC SYNCHRONOUS MOTORS & LINEAR ACTUATORS

HYBRID AC LINEAR ACTUATOR SERIES



CAN-STACK AC LINEAR  
ACTUATOR SERIES

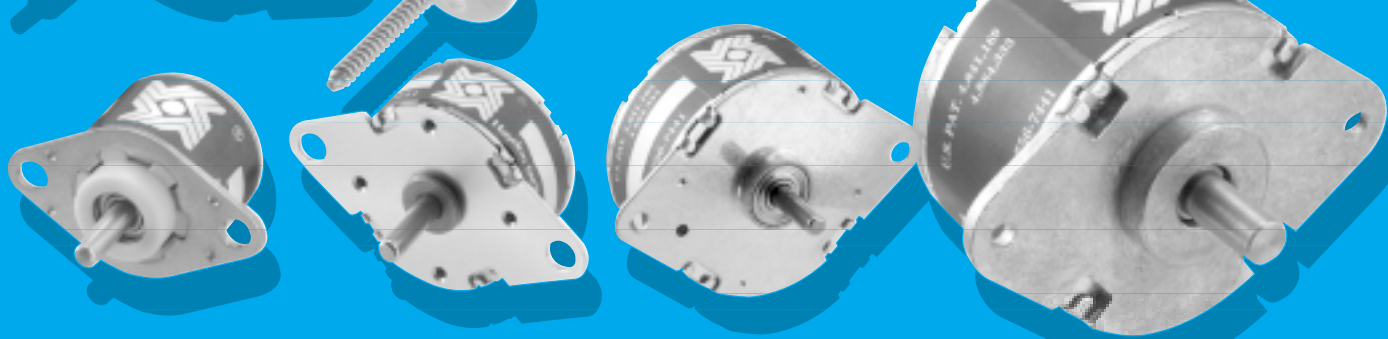

ROTARY AC MOTOR SERIES

1-800-243-2715 • WWW.HSI-INC.COM



Haydon Switch & Instrument

# AC Synchronous Motors

Stepping motors can also be run on AC (Alternating Current), however one phase must be energized through a properly selected capacitor. In some situations, depending on the impedance of the motor, the capacitor alone cannot produce a 90° phase shift between the two phases. Should this occur, a different winding for the capacitor coil is required or a resistor must be placed in series with the capacitor.

With AC motors however, the motor is limited to only one synchronous speed. For instance, if 60 Hz is being supplied, there are 120 reversals or alterations of the power source. The phase being energized by a capacitor is also producing the same number of alterations at an offset time sequence of 90 electrical degrees. The motor is actually being energized at the equivalent of 240 steps per second. For a 15° rotary motor, 24 steps are required to make one revolution. This becomes a 600 RPM synchronous motor.

$$\frac{240 \text{ steps per second} \times 60 \text{ seconds}}{24 \text{ Steps per revolution}} = 600 \text{ RPM}$$

In the case of a linear actuator, the linear speed produced is dependent on the resolution per step of the motor. For example, if 60 Hz is supplied to a .001"/step motor, the resulting speed is .240" per second (240 steps per second x .001"/step). Many of HSI's stepping motors are available as 300 or 600 RPM AC synchronous motors when used at 60 Hz.

Virtually instantaneous starting and stopping characteristics are one of the advantages of the synchronous stepping motors. Generally, the motor will start within 1<sup>1/2</sup> cycles of the applied frequency. The two conditions that determine the instantaneous starting direction are the position of the rotor prior to start and what portion of the AC sine wave is apparent when it is first applied to the motor windings. The motor may also momentarily start in the wrong direction, then quickly reverse and rotate in the correct direction. In most instances, this action is negligible.

If the load inertia is too great, the motor will not be able to accelerate within 1<sup>1/2</sup> cycles and, therefore, won't run. Ramping is not an option for AC motors. This problem can often be resolved by using a flexible coupling between the motor shaft and the load.

For mechanical dimensions of all HSI motors, please refer to our **Miniature Motors Product Catalog** and/or our **Hybrid Linear Actuator Products Catalog**, available in print or on-line.

**Mechanical Data**

Motor Part No.	Linear Speed @ 60 Hz		Linear Speed @ 50 Hz		Maximum Force	
	(inches/sec.)	(cm/sec.)	(inches/sec.)	(cm/sec.)	(lbs.)	(Newtons)
A35H4N-24	0.0288	0,073	0.0240	0,061	25	111
A35H4P-24	0.0375	0,095	0.03125	0,079	25	111
A35H4K-24	0.0576	0,146	0.0480	0,122	25	111
A35H4A-24	0.075	0,191	0.0625	0,159	20	89
A35H4J-24	0.1152	0,293	0.0960	0,244	15	69
A35H4B-24	0.1500	0,381	0.1250	0,318	12	53
A35H4Q-24	0.2304	0,585	0.1920	0,488	8	37
A35H4C-24	0.300	0,762	0.250	0,635	6	28
A35H4R-24	0.4608	1,170	0.384	0,975	4	18
A43K4U-24	0.0144	0,037	0.0120	0,030	50	222
A43K4V-24	0.0188	0,048	0.01563	0,040	50	222
A43H4N-24	0.0288	0,073	0.0240	0,061	50	222
A43H4P-24	0.0375	0,095	0.03125	0,079	50	222
A43H4K-24	0.0576	0,146	0.0480	0,122	50	222
A43H4A-24	0.075	0,191	0.0625	0,159	50	222
A43H4J-24	0.1152	0,293	0.0960	0,244	50	222
A43H4B-24	0.1500	0,381	0.1250	0,318	32	142
A43H4Q-24	0.2304	0,585	0.1920	0,488	30	133
A43H4C-24	0.300	0,762	0.250	0,635	18	80
A43H4R-24	0.4608	1,170	0.384	0,975	14	62
A57H4A-24	0.075	0,191	0.0625	0,159	140	623
A57H4S-24	0.100	0,254	0.0833	0,212	120	534
A57H43-24	0.120	0,305	0.100	0,254	110	489
A57H4T-24	0.200	0,508	0.1667	0,423	90	400
A57H41-24	0.240	0,610	0.200	0,808	75	334
A57H42-24	0.480	1,219	0.400	1,016	38	169
A87H43-24	0.120	0,305	0.100	0,254	500	2224
A87H4B-24	0.150	0,381	0.125	0,318	375	1668
A87H4C-24	0.300	0,762	0.250	0,635	190	845
A87H4Y-24	0.600	1,524	0.500	1,270	95	423
A87H4Z-24	1.200	3,048	1.000	2,540	50	222

Motor part numbers are for a captive shaft. **For a non-captive shaft**, change the middle letter from an “H” to an “F”.

Example 1: A35H47-24 with a non-captive shaft becomes A35F47-24.

**Exception:** A43K4U-24 and A43K4V-24, for a non-captive shaft substitute “J” in place of the “K”.

Example 2: A43K4U-24 with a non-captive shaft becomes A43J4U-24.

**For an external linear shaft**, add the three digit suffix - 800 to the captive shaft part number.

Example 3: A35H47-24 with an external linear shaft becomes A35H47-24-800.

All standard motors operate at 24 Volts, represented in the part number by the suffix - 24 (A35H47-24).



**Haydon Switch & Instrument**  
**AC Hybrid Linear Actuators**

All Hybrid Linear Actuators are available with captive, non-captive and external linear shaft designs.

### Electrical Data

Series	Size	Watts	AMPS	Capacitor	Capacitor	Coil Resistance		Connection Diagram
				(Mfd) @ 60 Hz	(Mfd) @ 50 Hz	(Ohms) Main Wind.	(Ohms) Cap. Wind.	
35000	14	5.0	0.21	20	20	152	38	4
43000	17	6.5	0.27	15	15	104	104	3
57000	23	13.0	0.60	30	40	35	35	3
87000*	34	30.0	2.00	200	200	23	23	5

\* With 12 OHM, 100 watt resistor in series

Diag. 3

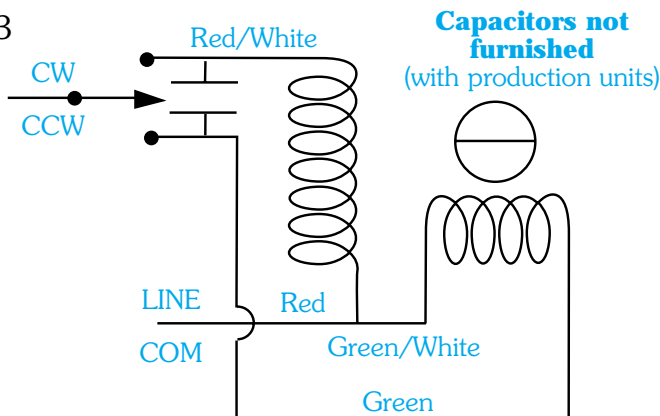

Diag. 4

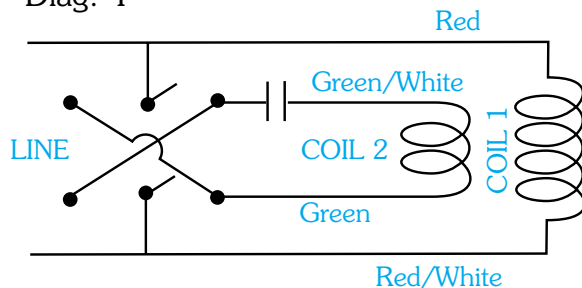

Diag. 5

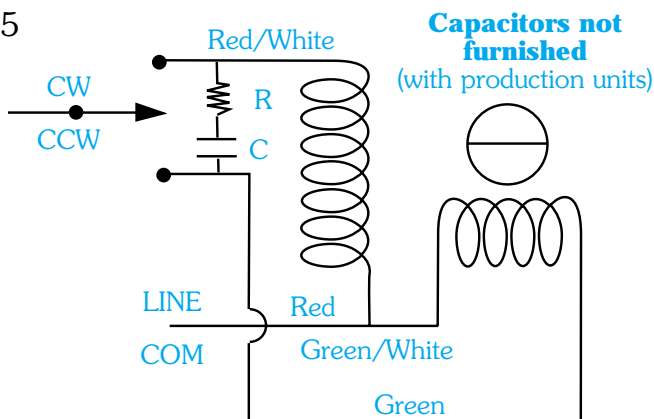

**For ROTARY HYBRID MOTORS, contact LIN ENGINEERING at 408.919.0200.**

All matters concerning services or merchandise desired from LIN ENGINEERING are solely between you and LIN ENGINEERING. We make no warranties or representations concerning, and shall have no liabilities or obligations with regards to, any such services or merchandise.



Haydon Switch & Instrument

# AC Linear Actuators Permanent Magnet Type

For electrical data refer to the Rotary Motor Chart

## Mechanical Data

Motor Part No.	Linear Speed @ 60 Hz		Linear Speed @ 50 Hz		Maximum Force	
	(inches/sec.)	(cm/sec.)	(inches/sec.)	(cm/sec.)	(lbs.)	(Newtons)
Z20541-24-700	0.24	0,610	0.20	0,508	5.5	24
Z20542-24-700	0.48	1,219	0.40	1,016	3.0	13
Z20544-24-700	0.96	2,438	0.80	2,032	1.8	8
A26443-24	0.12	0,305	0.10	0,254	7.4	33
A26441-24	0.24	0,610	0.20	0,508	4.4	20
A26542-24	0.48	1,219	0.40	1,016	3.5	16
A26544-24	0.96	2,438	0.80	2,032	2.0	9
Z26443-24-700	0.12	0,305	0.10	0,254	13.0	58
Z26441-24-700	0.24	0,610	0.20	0,508	8.3	37
Z26542-24-700	0.48	1,219	0.40	1,016	6.6	29
Z26544-24-700	0.96	2,438	0.80	2,032	3.3	15
A36443-24 **	0.12	0,305	0.10	0,254	16.0	71
A36441-24 **	0.24	0,610	0.20	0,508	12.0	53
A36442-24 **	0.48	1,219	0.40	1,016	6.0	27
A36544-24 **	0.96	2,438	0.80	2,032	3.0	13
A46443-24 **	0.12	0,305	0.10	0,254	43	191
A46441-24 **	0.24	0,610	0.20	0,508	34	151
A46442-24 **	0.48	1,219	0.40	1,016	20	89
A46544-24 **	0.96	2,438	0.80	2,032	11	49
A46548-24 **	1.92	4,877	1.60	4,064	5.4	24
A4654G-24 **	3.84	9,754	3.20	8,128	2.7	12

Motor part numbers are for a captive shaft. **For a non-captive shaft**, change the third digit from a "4" to an "3".  
*Example 1:* A26441-24 with a non-captive shaft becomes A26341-24. *Exception:* When the third digit is "5" for a non-captive shaft substitute "8". *Example 2:* A26544-24 with a non-captive shaft becomes A26844-24.

**For an external linear shaft**, add the three digit suffix - 800 to the captive shaft part number.  
*Example 3:* A26441-24 with an external linear shaft becomes A26441-24-800.

All standard motors operate at 24 Volts, represented in the part number by the suffix - 24 (A36443-24).

\*\* Select motors available with 24 Volts or 120 Volts (replace 24 with 120).



All Linear Actuators are available with captive, non-captive and external linear shaft designs.



Haydon Switch & Instrument

# AC Rotary Motors Permanent Magnet Type

**Series Z20000**  
Ø 20 mm (.79")



**Series 26000**  
Ø 26 mm (1.0")



**Series 36000**  
Ø 36 mm (1.4")



**Series 46000**  
Ø 46 mm (1.8")



Rotary motors are available with ball bearings (shown) or sleeve bearings.

## Electrical Data

Motor Part No.	Rotary Speed (RPMs) @		Torque (oz-in) (N-cm)		Watts	Amps	Capacitor @		Connection Diagram	Coil Resistance (Ohms)	
	60 Hz	50 Hz					60 Hz	50 Hz		Main Wind.	Cap. Wind.
Z20540-24-700	600	500	0.5	0,4	2.5	.15	12.5	12.5	2	300	75
A26440-24	300	250	0.9	0,6	3.4	.20	15.0	15.0	2	214	54
A26540-24	600	500	0.9	0,6	3.4	.20	15.0	20.0	2	214	54
Z26440-24-700	300	250	1.2	0,8	3.4	.19	15.0	15.0	2	214	54
Z26540-24-700	600	500	1.5	1,1	3.4	.19	15.0	15.0	2	214	54
A36240-24	150	125	2.5	1,8	4.6	.23	20.0	20.0	2	160	40
A36440-24	300	250	2.6	1,8	4.6	.23	20.0	20.0	2	160	40
A36540-24	600	500	1.3	0,9	4.6	.23	20.0	20.0	2	160	40
A46440-24	300	250	8.5	6,0	10.0	.38	20.0	20.0	1	29	29
A46540-24	600	500	6.5	4,6	10.0	.38	20.0	25.0	1	58	58
A36240-120	150	125	2.5	1,8	4.6	.05	0.8	0.8	2	4000	1000
A36440-120	300	250	2.6	1,8	4.6	.05	0.8	0.8	2	4000	1000
A36540-120	600	500	1.3	0,9	4.6	.05	0.8	0.8	2	4000	1000
A46440-120	300	250	8.5	6,0	10.0	.08	0.8	0.8	1	725	725
A46540-120	600	500	6.5	4,6	10.0	.08	0.8	1.0	1	1450	1450

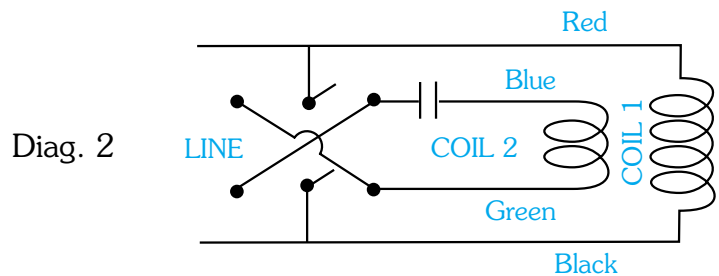
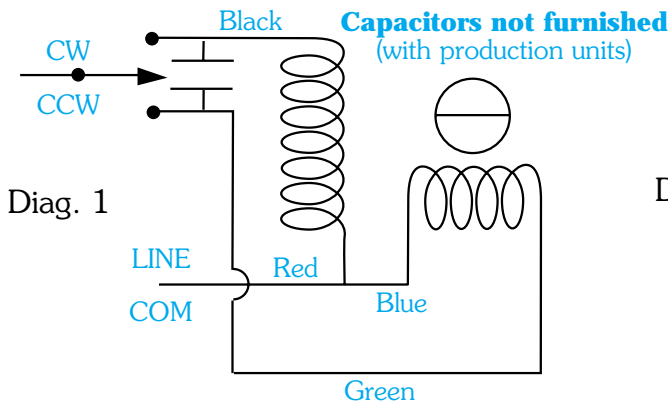

Haydon Switch & Instrument

1500 Meriden Road  
Waterbury, Connecticut 06705 USA

[www.hsi-inc.com](http://www.hsi-inc.com)

Call free 800.243.2715

(International call 203.756.7441)

Fax: 203.756.8724