

REVISIONS			
REV.	DESCRIPTION	DATE	ECO NO.

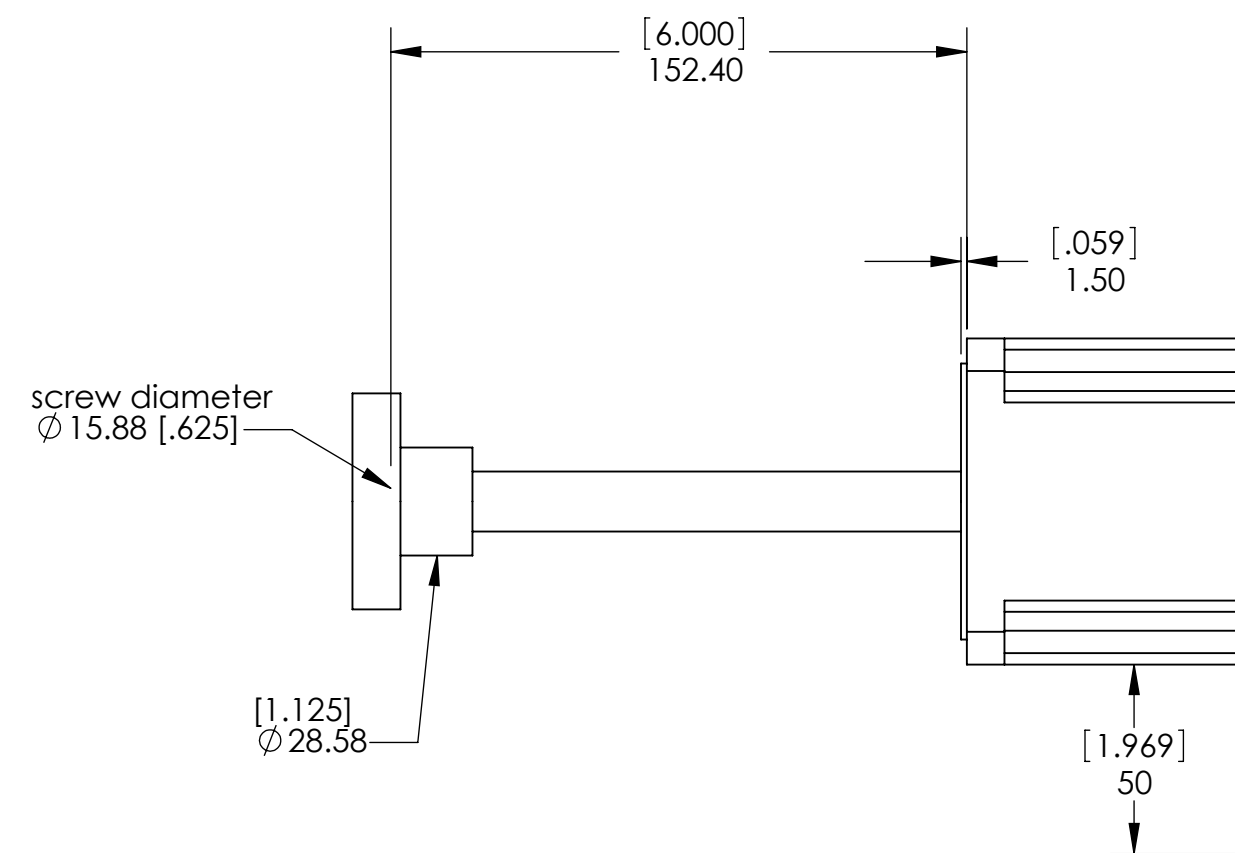
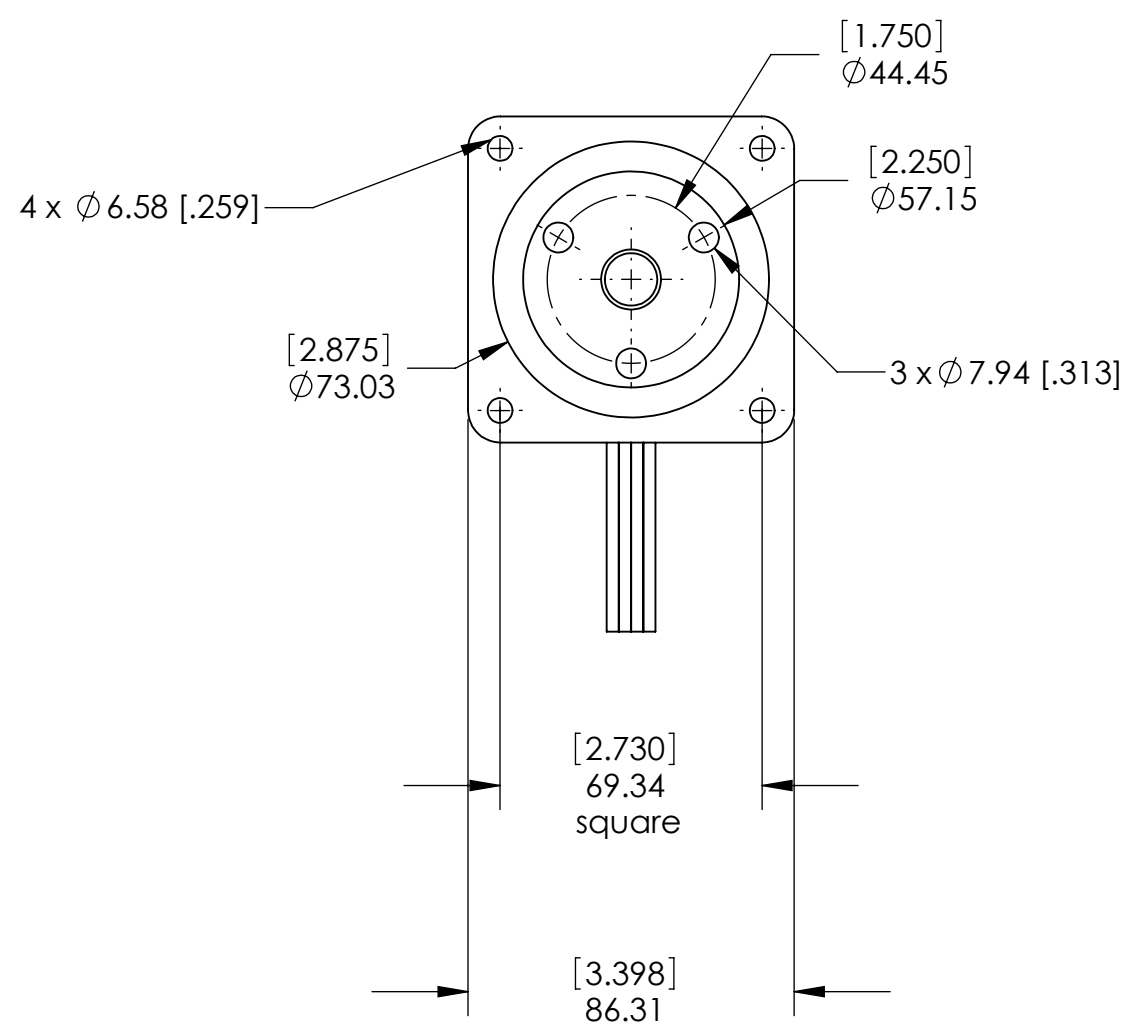
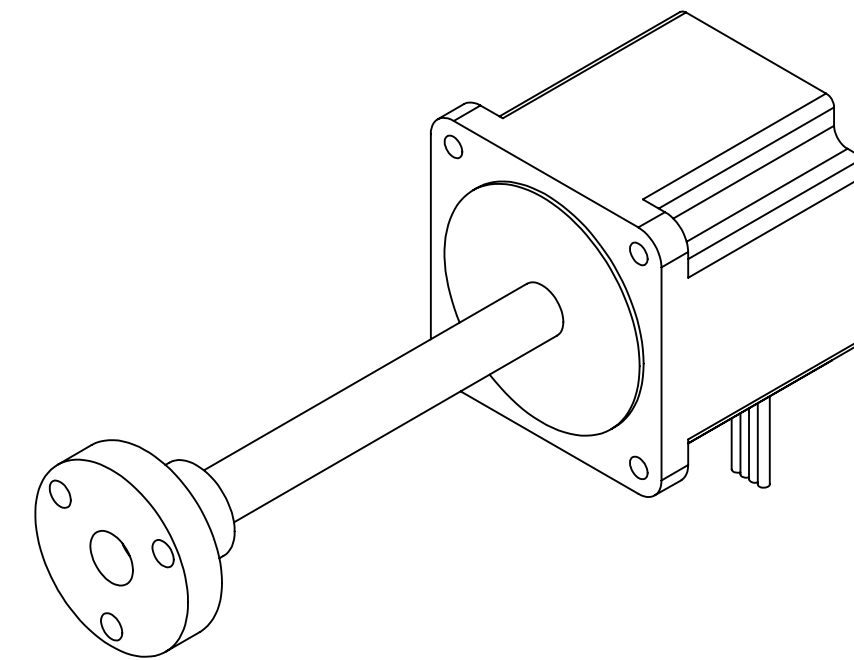
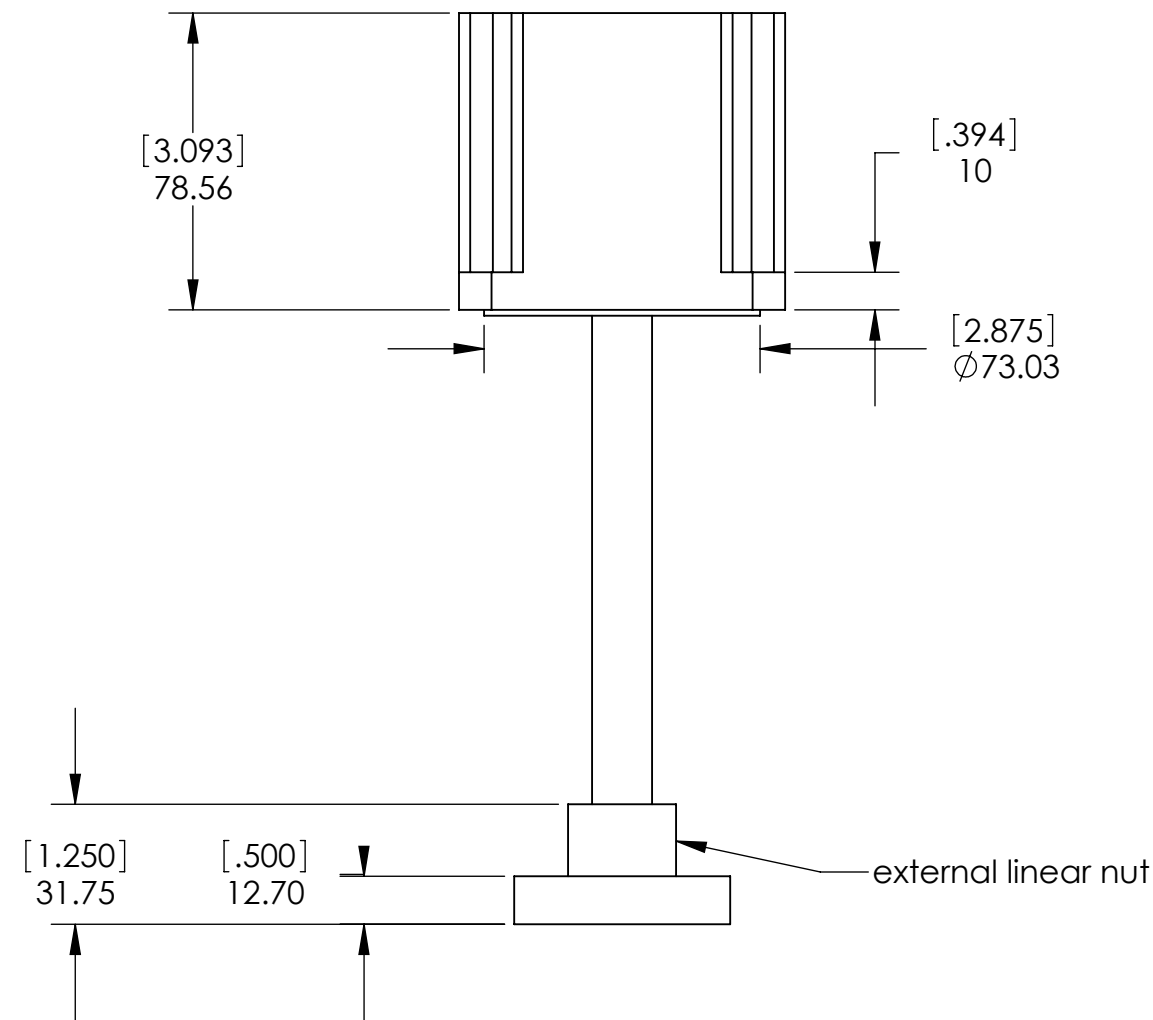

PARTNUMBER : E87H43-2.85-6-12

MATERIAL	<p>THE FOLLOWING ITEMS APPLY UNLESS OTHERWISE SPECIFIED:          FOR FEATURES OF SIZE, PERFECT STRAIGHTNESS NOT REQUIRED AT MMC. FOR DIAMETRAL FEATURES, ROUNDNESS MUST BE WITHIN THE MMC AND LMC BOUNDARY. TRUE POSITION TOLERANCE AND RELATED DATUMS (EXCEPT PLANE SURFACES), APPLY AT MMC. OTHER GEOMETRIC TOLERANCES, AND RELATED DATUMS, APPLY RFS, SEPARATELY, REGARDLESS OF DATUM.</p> <p><b>GEOMETRIC DRAWING SYMBOLS</b></p> <p>— FLAT    / RUNOUT    ○ ROUND    ∠ ANGULAR          — STRAIGHT    ⊕ TRUE POSITION    / CYLINDRICAL    ⊙ CONCENTRIC          ⊥ SQUARE    // PARALLEL    = SYMMETRICAL    ⌀ DIAMETER          ⌒ PROFILE OF A SURFACE    — PROFILE OF A LINE          ⊖ MAXIMUM MATERIAL CONDITION (MMC)    ⊕ PROJECTED TOLERANCE ZONE</p>
HEAT TREAT SPEC.	
FINISH	

ALL SIGNATURES REQUIRED FOR APPROVAL AND ORIGINAL DRAWING MASTERS ARE CONTROLLED ELECTRONICALLY.

DRAWN BY

DIMENSIONS ARE IN MILLIMETERS UNLESS OTHERWISE SPECIFIED

DECIMALS: X: ±.38  
 DECIMALS X.X: ±.25  
 DECIMALS X.XX: ±.13  
 ANGLES: ±2°

Haydon Switch and Instrument, Inc.  
 Waterbury, Connecticut 06705 U.S.A

TITLE

*87000 Series External Linear Actuator*

CODE IDENT. NO.	DWG. SIZE	DWG. NO.
<b>02005</b>	<b>C</b>	<i>87000_External_Linear</i>

NOTICE TO ALL PERSONS RECEIVING THIS DRAWING

THIS DRAWING IS ONLY CONDITIONALLY ISSUED, AND FOR THE SOLE PURPOSE OF INFORMING LICENSEE AND ASSOCIATE CONTRACTORS OF HAYDON SWITCH & INSTRUMENTS, INC. AND VENDORS THEREOF AND CUSTOMERS THEREOF. RECEIPT OR POSSESSION THEREOF DOES NOT CONFER TO TRANSFER ANY RIGHTS IN THE SUBJECT MATTER OF THE DRAWING. THE DESIGN, CONSTRUCTION, TECHNICAL INFORMATION AND ALL OTHER SUBJECT MATTER SHOWN ON THIS DRAWING ARE AND REMAIN, EXCEPT AS MAY BE OTHERWISE INDICATED BY WRITTEN NOTICE HEREON, THE EXCLUSIVE PROPERTY OF SAID CORPORATION. THIS DRAWING MAY BE REPRODUCED ONLY BY LICENSEE AND ASSOCIATE CONTRACTORS OF SAID CORPORATION AND ONLY FOR LICENSED MANUFACTURE AND BY VENDORS MANUFACTURING FOR SAID CORPORATION, ITS LICENSEE OR ASSOCIATE CONTRACTORS.